

# Design and Fabrication of Alternate Energy Storage Device using PCM

Prabhu M\*, P.L. Ramalingam, R. Manivannan, G. Naveen, Balasubramanian K

Department of Mechanical, Panimalar Institute of Technology, Chennai, India

\*Corresponding author: E-Mail: muthuprabhu99@gmail.com

## ABSTRACT

The use of a latent heat storage system using phase change materials is an effective way of storing thermal energy. In this project a PCM based tube in shell heat exchanger is designed and fabricated. The project focuses on the temperature distribution pattern of the phase change material during the process of charging and discharging the results are obtained by experimentally. Paraffin wax has been used as the phase change material. This type of thermal energy storage system can be used as a medium to store energy and can be used further.

**KEY WORDS:** PCM, Solar Water Heater, Thermocouple Wire.

## 1. INTRODUCTION

The continuous increase in the level of greenhouse gas emissions and the increase in fuel prices are the main driving forces behind efforts to more effectively utilize various sources of renewable energy. In many parts of the world, direct solar radiation is considered to be one of the most prospective sources of energy. One of the options is to develop energy storage devices, which are as important as developing new sources of energy. The storage of energy in suitable forms, which can conventionally be converted into the required form, is a present day challenge to the technologists. The use of a latent heat storage system using phase change materials (PCMs) is an effective way of storing thermal energy and has the advantages of high-energy storage density and the isothermal nature of the storage process. There are large numbers of PCMs that melt and solidify at a wide range of temperatures, making them attractive in a number of applications. The project includes testing of a small heat exchanger, in order to establish the effectiveness of using paraffin wax as a suitable phase change material. The paraffin wax is incorporated in the heat exchanger, which acts as thermal energy storage device. This device will then be tested on a test rig for water heating and other applications.

**Objective:** The objective of this project is to design and fabricate a tube in tube, phase change material (PCM) based heat exchanger, which can act as a thermal energy storage device, and hence can be incorporated in solar water heater. The thermal energy storage device will act as a short term energy storage device.

## 2. EXPERIMENTAL SETUP

### PCM in solar water heater:

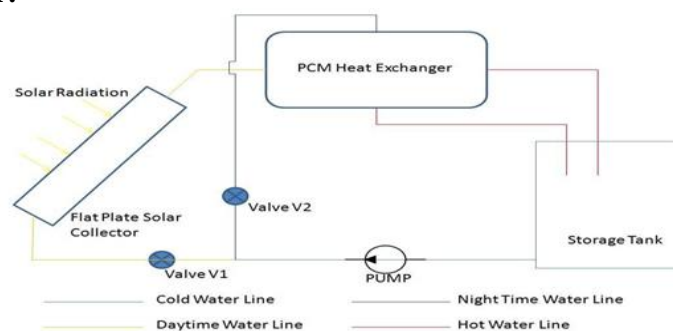

**Figure.1. Outline of thermal energy storage with solar water heater**

**Working:** During sunshine period, valve 1 is kept open and valve 2 is kept closed. The cold water from the storage tank goes through the flat plate solar collector, absorbing heat energy from the solar radiations. It then passes through the PCM heat exchanger, where it loses its heat to the phase change material. It then goes back to the storage tank. In this way, the PCM gains heat energy which will then be used to heat water during non-sunshine period.

During non-sunshine period, valve 1 is kept closed and valve 2 is kept open. The cold water from the storage tank goes through the PCM heat exchanger, absorbing heat energy from the heat stored in the phase change material. It then goes back to the storage tank. By this way cold water is heated with the help of heat stored in the PCM.

**Designing PCM Based Heat Exchanger:** The calculation for the PCM based heat exchanger is done in the following steps:

**Amount of hot water required:** Usually, in a typical household, during non-sunshine period, requirement of water is around 3 buckets. Taking volume of each bucket as 20 litres, total requirement will amount to 60 litres. However for our experimental purpose we consider designing of a heat exchanger to heat 10 kg of water. The same approach may be adopted to design a system of higher requirement.

**Amount of heat energy to be stored:** During winter season, the average temperature at which the water is available in the tanks is around 15-20°C. Temperature of water required for comfortable bathing during winter season is around

40°C. Hence the amount of temperature difference we need to attain for comfortable bathing is 20-25°C.

Initial temperature of water  $T_i = 15^\circ\text{C}$

Final (desired) temperature of water  $T_f = 40^\circ\text{C}$

$T_f - T_i = 25^\circ\text{C}$

Heat capacity of water,  $C_v = 4.187 \text{ kJ/kg}$

Hence, amount of heat required to carry out the above transition = Q

$$Q = m_{\text{water}} \times (T_f - T_i) \times C_v$$

$$\text{i.e. } Q = 10 \times 25 \times 4.187 = 1046.75 \text{ kJ}$$

Hence, amount of energy needs to be stored = 1046.7 kJ

**Selection of suitable heat exchanger:** A tube in shell type heat exchanger is the simplest choice of heat exchanger. Incorporation of phase change material is also easy in this type of exchanger. The phase change material is incorporated in the outer shell of the heat exchanger and the heat transfer fluid (HTF), which is water in this case, flows from the inner tube.

**Selection of suitable phase change material:** Selection of a suitable phase change material is very important and is the fundamental requirement of our project. The paraffin wax has high latent heat capacity of 206 kJ/kg. The phase transition temperature of the wax is 40°C to 50°C, which is suitable for our requirement. The change in volume of wax from solid to liquid is negligible. The wax is chemically stable and does not affect any component of the heat exchanger. Above all, wax is available at low cost.

**Table.1. Thermal properties of paraffin wax**

<b>Transition temperature</b>	40°C to 50°C
<b>Latent heat capacity</b>	206 kJ/kg
<b>Density</b>	789 kg/m <sup>3</sup>

**Estimation of amount of PCM:** The amount of PCM to be incorporated is estimated as follows:

Amount of energy to be stored=Q=1046.75 kJ

Hence mass of PCM to be incorporated = Q/(Latent heat) = 1046.45/206 = 5.0816 kg. Hence approximately 5.1 kg of PCM needs to be incorporated in the heat exchanger.

**Calculation of dimensional parameters of heat exchanger:**

The number of energy storage units to be used =n=7

Length of each energy storage unit=0.5m

Mass of PCM in each unit =  $m_{\text{pcm}}/n$

$$\text{i.e. } m_{\text{pcm/unit}} = 5.0813/7 = 0.7259 \text{ kg}$$

Volume of PCM to be used =  $m_{\text{pcm/unit}} \times \rho$

$$\text{i.e. } V_{\text{pcm}} = 0.7259 \times 789 = 0.00092002 \text{ m}^3$$

Hence, the cross sectional area of outer portion of heat exchanger

$$A_2 = V/L = 0.00092002/0.5 = 0.00184005 \text{ m}^2 = 18.4 \text{ cm}^2$$

Assuming a suitable diameter for the internal pipe.

We select a standard diameter of copper pipe = 1.4 cm

Hence, cross sectional area of the internal pipe =  $A_1 = 1.5393 \text{ cm}^2$

Total cross sectional area of the Heat Exchanger unit =  $A_1 + A_2$

$$\text{i.e. } A = A_1 + A_2 = 1.5393 + 18.4 = 19.939 \text{ cm}^2$$

Hence, the internal diameter of outer pipe =  $\frac{1}{4} \times ((A_1 + A_2)/\pi)^{1/2} = 5.038 \text{ cm} = 2''$

**Testing Of Single Energy Storage Unit:** The single energy storage is tested on a test rig. The temperatures are measured at discrete points. The following parameters of the energy storage unit are measured:

- Inlet and outlet temperatures of heat transfer fluid at specific intervals.
- Temperature distribution of wax during charging and discharging at specific intervals.
- The temperatures are recorded at the points

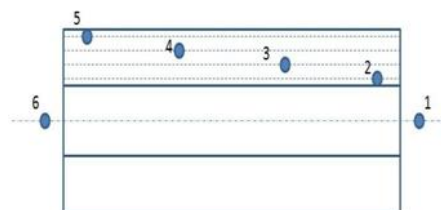

**Figure.2. Temperature measurement points in an energy storage unit**

**Construction of test rig:** The testing involve, vertically mounting the single energy storage unit. The single energy storage unit is vertically mounted on inverted 'T' stand. The mounting is done in such a way that the inlet of heat transfer unit is from the below and its outlet is at the top. The heat transfer fluid, which is water in this case, is stored

in a suitable storage tank. The water is routed through a suitable connecting pipe, through pump and a flow control valve. The heat transfer fluid is then sent back to the storage tank when it comes out of the outlet through connecting pipe. A suitable arrangement of heating the water is done in the storage tank. This is being done to eliminate the flat plate collector from the circuit. During charging, the pump creates a circulation in the circuit. The heat transfer fluid comes from the storage tank, through the flow control valve, to the inlet of the energy storage unit. The water after losing its heat in the energy storage unit goes back to the storage tank. During discharging, the heating arrangement of the storage tank is kept off and water in the tank is kept at ambient temperature. The pump creates the circulation and water comes from storage tank, through flow control valve, to the inlet of the energy storage unit. The water after gaining heat from the stored heat of PCM in energy storage unit goes back to the storage tank. The thermocouple wires are incorporated at predetermined points of the energy storage unit. The temperature outputs of the thermocouple are taken with help of an 8 channel temperature indicator, which will indicate temperature of the wax and inlet and outlet temperature of the heat transfer fluid.

#### Components of test rig:

**Energy storage unit:** The energy storage unit is the main component of the test rig. The heat transfer fluid flows from the inner copper pipe. The outer pipe is of PVC, which also acts as insulating material. It prevents the melted wax to solidify after charging. The paraffin wax is incorporated in the outer pipe of the energy storage unit.

**Storage tank:** The purpose of the storage tank is to act as a reservoir of water which will be circulated in the circuit. Ideally the storage tank should be insulated to prevent any exchange of heat through it.

**Pump:** The purpose of the pump is to create a circulation in the circuit. The pump used in the circuit is a non-submersible water pump with a head of 6 feet.

**Heating coil:** The purpose of the heating coil is to heat the water in the storage tank. The heating coil used in the setup is of 1500 W rating.



Figure.3. Energy storage unit



Figure.4. Storage tank



Figure.5. Pump



Figure.6. Heating coil

**Flow control valve:** The purpose of flow control valve is to regulate the mass flow rate of the heat transfer fluid through the circuit.

**Thermocouple wire:** The thermocouple wire used for temperature measurement is of J-Type. The two dissimilar metal wires used in this thermocouple are of iron and constantan. Before inserting the thermocouple at the points, ends of the two metal wires are joint using a gas welding flame to form a bead.

**Temperature indicator:** The temperature indicator consists of 8 channels. Each channel receives input from different thermocouples which are incorporated in the energy storage unit.



Figure.7. Flow control valve



Figure.8. Thermocouple wire



Figure.9. Temperature indicator

**Testing procedure:** The testing of the energy storage unit is done in two modes, charging and discharging. The temperature distribution of phase change material is studied in each mode to study melting and solidification pattern of the phase change material.

**Charging:** The procedure of testing in charging mode is as follows:

- The water of storage tank is heated to the range of 80-85°C, using the heating arrangement.
- The flow control valve is adjusted to a suitable mass flow rate of heat transfer fluid.
- The initial readings of the temperature indicator are recorded.
- The pump is switched on to initiate the flow in the circuit.
- The readings of temperature indicator i.e. temperature at the predetermined points are then taken at an interval of 2 minutes, for around 40 to 60 minutes.
- The variation of temperature at each point in the wax is then plotted against time elapsed.

**Discharging:** The procedure for testing in discharging mode is as follows:

- The heating arrangement of the storage tank is kept off.
- The initial readings of the temperature are recorded.
- The water in the storage tank at ambient temperature is circulated using the pump.
- The readings of temperature indicator i.e. temperature at predetermined points are taken at an interval of 2 minutes for around 40 to 60 minutes.
- The variation of temperature at each point in the wax is then plotted against the time elapsed.

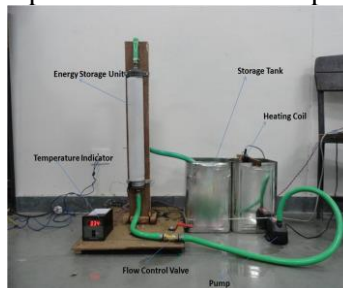

**Figure.10. prototype**

#### 4. CONCLUSION

Paraffin wax is a good PCM for energy storage in latent heat storage system. It has a suitable transition temperature range of 45-55°C and a relatively high latent heat of 206 kJ/kg. In addition, it does not exhibit any sub-cooling. A simple tube-in-tube heat exchanger system can be used for energy storage with reasonable charging and discharging times. The melting was more at the top and nearer to the inner tube. The solidification was rapid at the point which was nearer to the inner tube carrying heat transfer fluid.

The given arrangement can be used to store thermal energy in solar water heating application. The cost to incorporate the system is also very economical. The primary objective of using paraffin wax as a PCM material has been successfully experimented. This project is highly feasible and more than the feasibility this project can overcome the energy crisis to greater extent.

#### REFERENCES

- Al-Abidi A.A, Mat S.B, Sopian K, Sulaiman M.Y, Lim C.H & Th A, Review of thermal energy storage for air conditioning systems, *Renewable and Sustainable energy reviews*, 16 (8), 2012, 5802-5819.
- Demirbas M, Fatih, Thermal Energy and Phase Storage Change Materials, An Overview, *Energy Sources, Part B*, 1, 2006, 85-95.
- James, Brian, Delaney, Paul, Phase Change Materials, Are Efficient Future? *ACEEE Summer Study*, 3, 2012, 160-172.
- Jesumathy S.P, Udayakumar M & Suresh S, Heat transfer characteristics in latent heat storage system using paraffin wax, *Journal of mechanical science and technology*, 26 (3), 2012, 959-965.
- Sharma A, Tyagi V.V, Chen C.R & Buddhi D, Review on thermal energy storage with phase change materials and applications, *Renewable and Sustainable energy reviews*, 13 (2), 2009, 318-345.
- Trp, Arnica, An experimental and numeric technical grade paraffin melting and solidification in a shell and tube latent thermal energy storage unit, *660 Solar, Energy*, 79, 2005.